

ADD ULTRASONIC WATER METER DESIGNED FOR SMART WATER SOLUTION



The ADD smart water meter is based on the proven ultrasonic technology and advanced leakage control. The meter maintains its high accuracy throughout its entire lifetime of up to 16 years and allows integration in AMI systems within water/heat/gas/electricity complete solution.

FEATURES

Proven Ultrasonic Technology



- Flow sensor based on proven ultrasonic measurement;
- Two ultrasonic transducers used to send sound signals with/against the flow;
- Not exposed to wear due to impure water;
- Reliability in the long run exploitation.

Non-revenue water reduction



- Constant monitoring of water consumption;
- Leakage control and report;
- Reliable billing;
- Reduction of non-revenue water consumption and expenses.

Accuracy



- High accuracy meter:
- Accuracy class 2;
 - No moving parts ensures the same accuracy during the entire lifetime;
 - Low start flow down to 2 l/hour provides measurement of very low flows;
 - The flow velocity does not influence the meter accuracy.

Communication



Flexible communication options include:

- RF for WAN;
- Bluetooth to control ADD shut-off valve.

Intelligent Alarms



Supports the following alarm types:

- Leakage;
- Burst;
- Dry;
- Reverse flow;
- Tampering.

Provides indication on the display.

Data Registering and Storage



- The meters record hourly, daily, monthly data on water consumption;
- Leakage and tampering reports to analyze troubleshooting;
- Daily data storage capacity is not less than 24 months.

Display

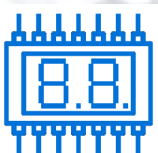

- LCD, 8 digits, easy readable;
- View of measurement data, states, info codes;
- WAN signal level indication.

Measurement



- Dual temperature monitoring: the meter records the ambient temperature and the water temperature;
- Target volumes can be selected from a wide range;
- Max & min flows depends on the chosen configuration.

Battery



- The meter is equipped with a lithium battery;
- Battery lifetime up to 16 years under normal operating conditions.

Design



- The meter case is made from durable composite material;
- Brass or composite measuring pipe;
- Meter houses are sealed and fully water resistant;
- IP68 Protection class;
- Metrological test output to control the metrological parameters during verification;
- Display to view measurement data and alarms;
- Easy mounting onto a water pipe;
- Suitable for outdoor installation.

Standards



Compliant with:

- ISO 4064 (OIML R49)
- MID Directive (2014/32/EU)

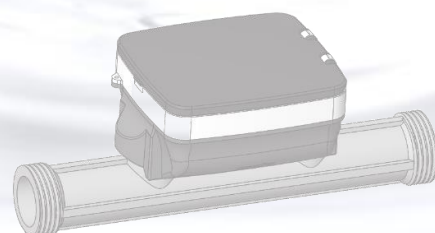

TECHNICAL SPECIFICATIONS



Characteristic	Value		
Model	WMP15	WMP20	WMP25
Nominal diameter	DN15	DN20	DN25
Permanent flow rate, Q3 (m³/h)	1.6 2.5	2.5 4	4 6.3
Dynamic range Q3/Q1	R250 R400		
Installation sensitivity class	U0/D0		
Temperature class	T50 (0.1 – 50 °C)		
Storage temperature	From -40 to 70 °C		
Metrological class	Class 2		
Maximum operation pressure	1.6 MPa		
Pressure loss	Δp40		
Protection class	IP68		
Environmental class	E2, M1		
Installation	Horizontal or vertical		
Battery	Lithium battery, up to 16 years lifetime in case of meter reading once per day		
Interfaces	Bluetooth		
WAN Communication	LoRaWAN or WM-BUS, SigFox (optionally) Different frequency ranges (optionally): 433 MHz, 868 MHz, 915 MHz, 923 MHz.		
Metrological LED	10 ⁻⁵ m ³ /imp		

Dimensions (mm)	WMP15	WMP20	WMP25
Measuring pipe length			
- Brass	110/165	130/195	190/225
- Composite	110	130	150
WM dimensions (HxDxB)			
- Brass	73x80x92	78x80x92	85x80x110
- Composite	73x80x92	78x80x92	80x80x92

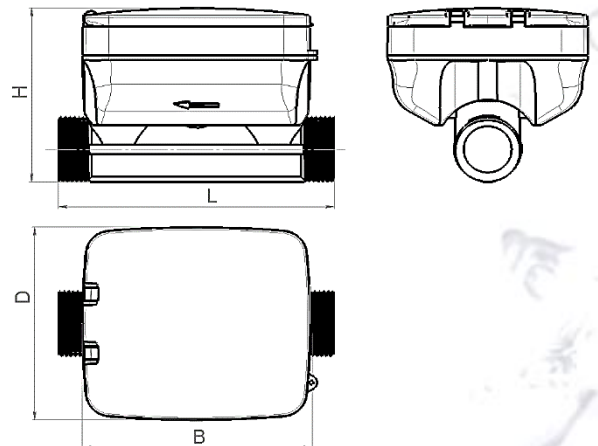

36, Dragomirna str. Kishinev, MD-2008, Republic of Moldova
Phone: +373 22 930 012 **Fax:** +373 22 930 012

